

POWERFLEX®

PART NUMBER

PFF80-1211

DESCRIPTION

REAR UPPER ARM OUTER BUSH

INSTALLATION GUIDE

Contents (parts per pack):

- | | |
|-------------------------------|-------------------------------|
| 2 x Bush Assembly | 2 x Stainless Steel B Sleeves |
| 2 x Stainless Steel A Sleeves | 1 x Grease |
| 4 x Rubber Dust Covers | |

Please read the complete fitting instructions and check package components before fitment. These fitting instructions are to be used as a guide and in conjunction with workshop manual.

It is recommended that:

- all work to be carried out by a licensed technician;
- all safety precautions adhered to;
- wheel alignment to be checked and adjusted as required after any suspension work.
- All fasteners must be tensioned to manufacturer's torque settings.

Fitting Instructions:

1. Remove the original spherical bush from the rear upper arm. This will require the bush to be pressed out.
2. Clean any dirt and corrosion from the bore of the wishbone, and file off any sharp edges with a rounded file.
3. Push the bush assembly into the wishbone with the tapered end leading. Press only on the flat top of the shell until and not on the centre washer.
4. Place the stainless-steel sleeves into the holes of the rubber dust covers as shown in Fig. 1. Sleeve A fits to the front side of the arm and sleeve B fits to the rear side of the arm.
5. Squeeze some of the supplied grease into the underside of the dust covers. This helps to further protect the internal bearing from any dust or water ingress.
6. Present the dust covers with sleeves to the bush and compress them slightly until the sleeves are touching the internal bearing within the bush.
7. Refit the arm to vehicle and tighten all fasteners to the manufacturer's torque settings.

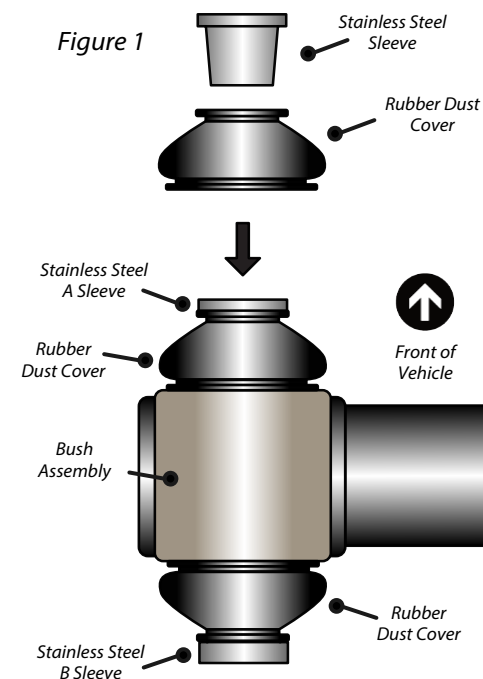

Figure 2

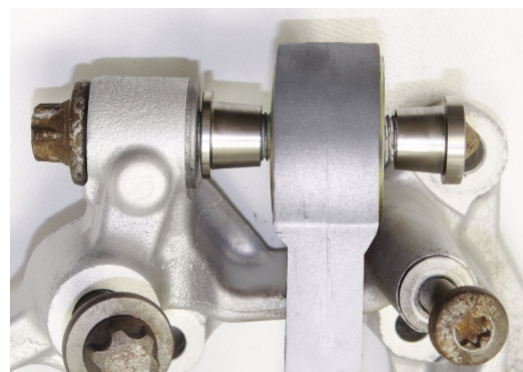

Figure 3 - Fitted